

QMODP1xx-02 15-70W

Q-switch driver

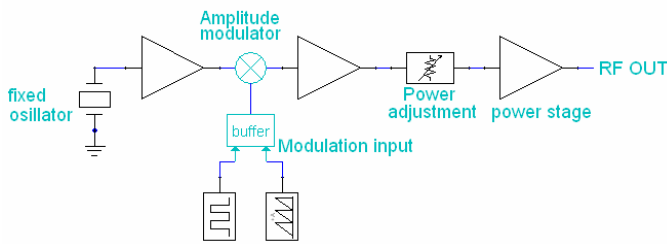

Specifications

Carrier frequency	24, 27.12, 40.68, 68.0 or 80 MHz
Frequency stability	+/-1 ppm/°C
Power Supply	24 VDC - nom 6 A @70 W (< 6.5 A), nom 3 A @20 W
Rise Time / Fall time (10-90 %)	< 50 ns typ 30ns
DPC control (Digital Pulse Control)	TTL reversed / 1 kΩ, PULL DOWN
Analog power control	analog 0-5 V / 1 kΩ Type PAC : RF OFF LEVEL Control
Maximum RF power adjustment	*with external potentiometer *Analog 0-5V / 1 kΩ
Extinction ratio	> 45 dB, typ 50 dB
Output RF power	15, 20, 30 or 70 Watts
Output Power Measurement	Analog signal through Pin 6 (load 1 Kohms)
Returned Output Power Measurement	Analog signal through Pin 8 (load 1 Kohms)
Output Impedance	50 Ω
V.S.W.R.	Nom < 1.5/1
RF connector	BNC
Controls connector	DB15
Thermal security QST	SMC / for Q-switch (Possibility to disable / switch)
Thermal Alarm QST	TTL Signal through Pin 5 (default indication for QST)
Thermal security DRIVER	Driver Automatic switch off for Tcase>70°C
Thermal Alarm driver	TTL Signal through (default indication for driver)
Size	143 x 110 x 20 mm ³
Weight	635 g
Heat exchange	CONDUCTION THROUGH BASEPLATE MUST BE ATTACHED ON A HEATSINK OR WATER COOLED PLATE
Operating temperature / Case Temperature	10 to 70 °C
Warm up time	Immediate use (15 min for maximum output power stability)

PIN CONNECTIONS

- Pin 1 PAC
 2 GND
 3 TTLR
 4 GND
 5 Output THERMAL PROTECTION AO (5V OK, 0V too hot)
 6 Output V incident
 7 GND
 8 Output V reflected
 9 FAC(Padj 0-5V)
 10 GND
 11 +5V out(pour relier à FAC si besoin)
 12 GND
 13 NC
 14 GND
 15 Output THERMAL PROTECTION driver (5V OK, 0V too hot)

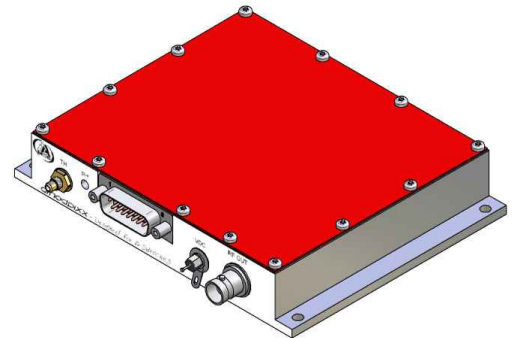

Outline Drawing

sizes in mm OEM Version

